

1 DLLR SPACE PLAN
SCALE: 1/4" = 1'-0"

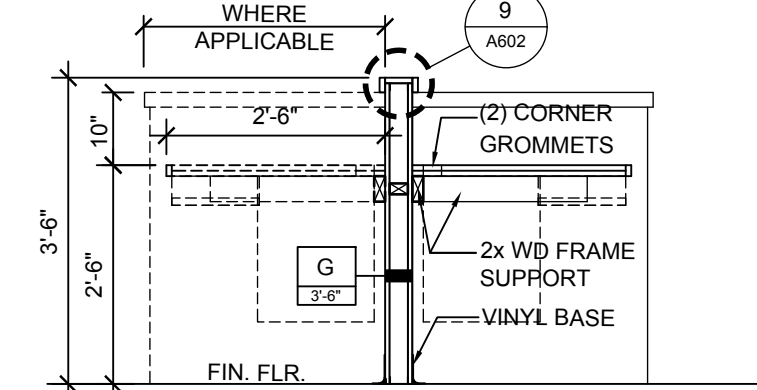

2 TYPICAL COMPUTER STATION
SCALE: 1/2" = 1'-0"

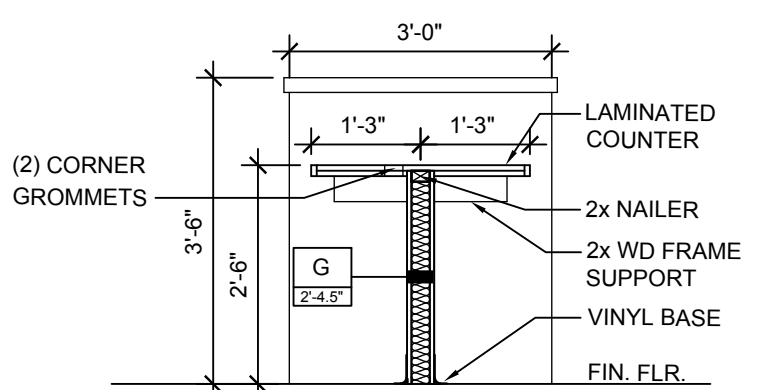

3 RECEPTION DESK
SCALE: 1/2" = 1'-0"

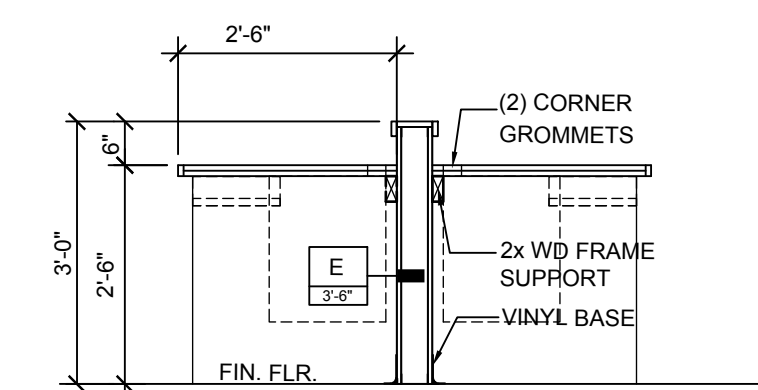

7 EXTRA RESOURCE
SCALE: 1/2" = 1'-0"

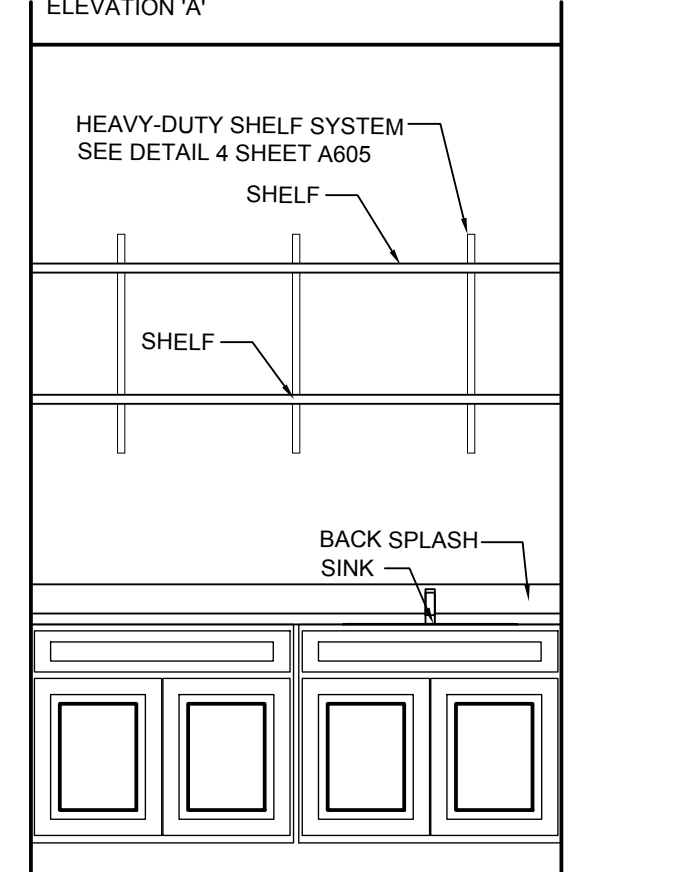

8 EXTRA RESOURCE
SCALE: 1/2" = 1'-0"

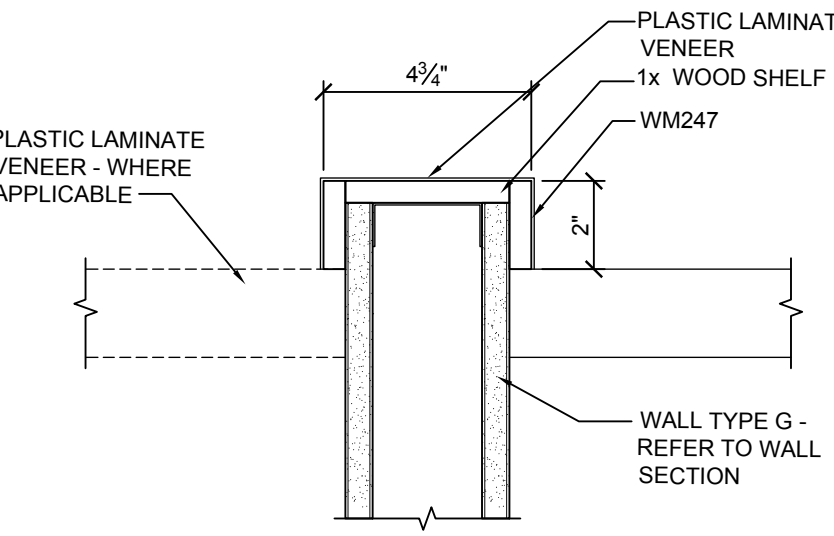

9 TYPICAL DETAIL
SCALE: 3" = 1'-0"

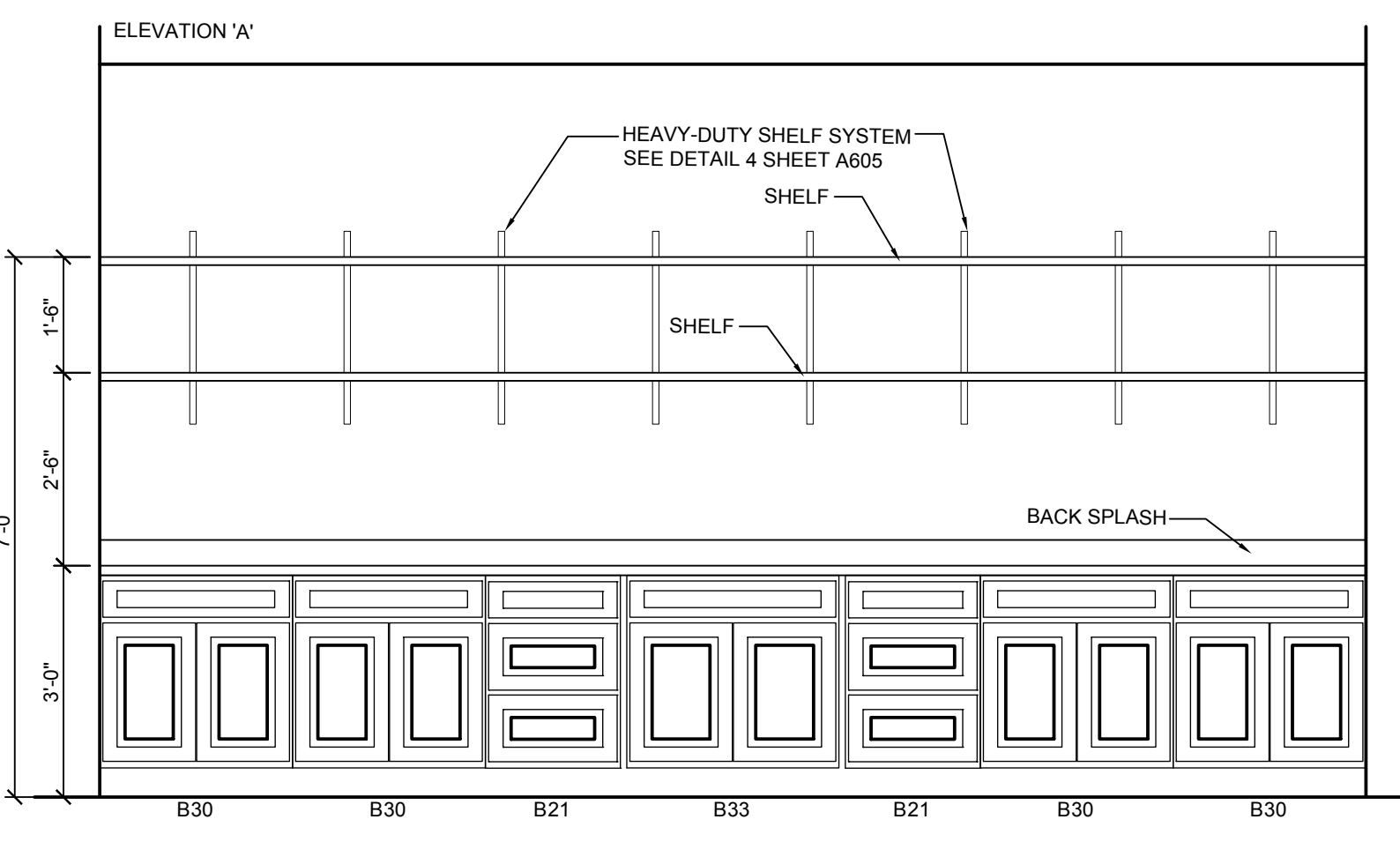

4 INTERIOR ELEVATION
SCALE: 1/2" = 1'-0"

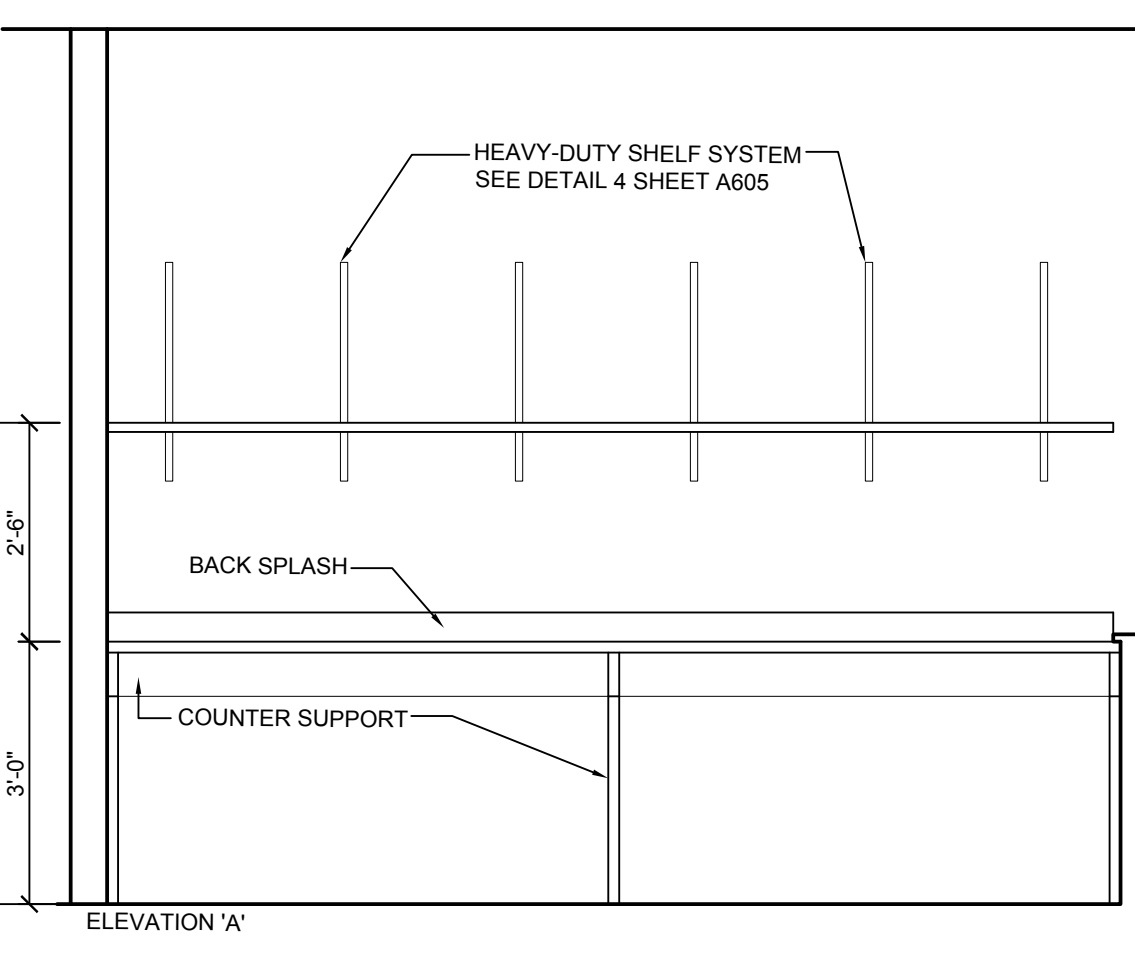
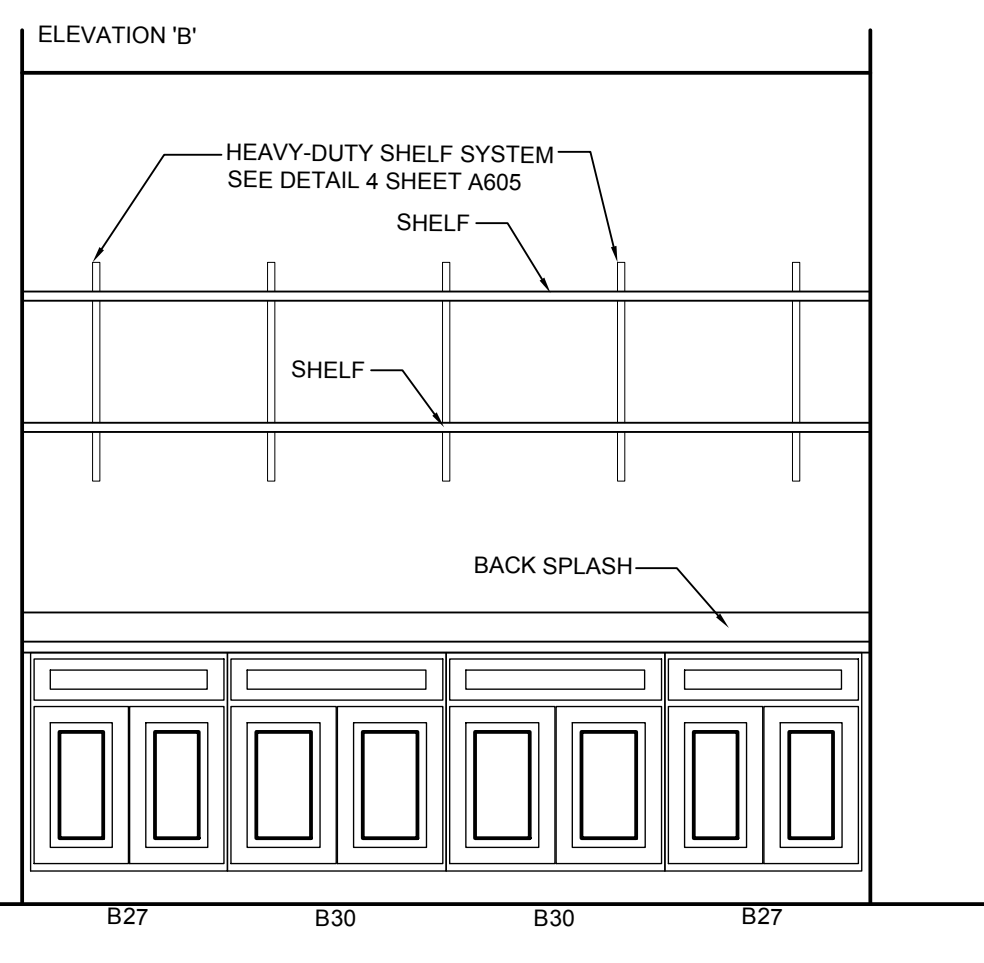

5 INTERIOR ELEVATION
SCALE: 1/2" = 1'-0"

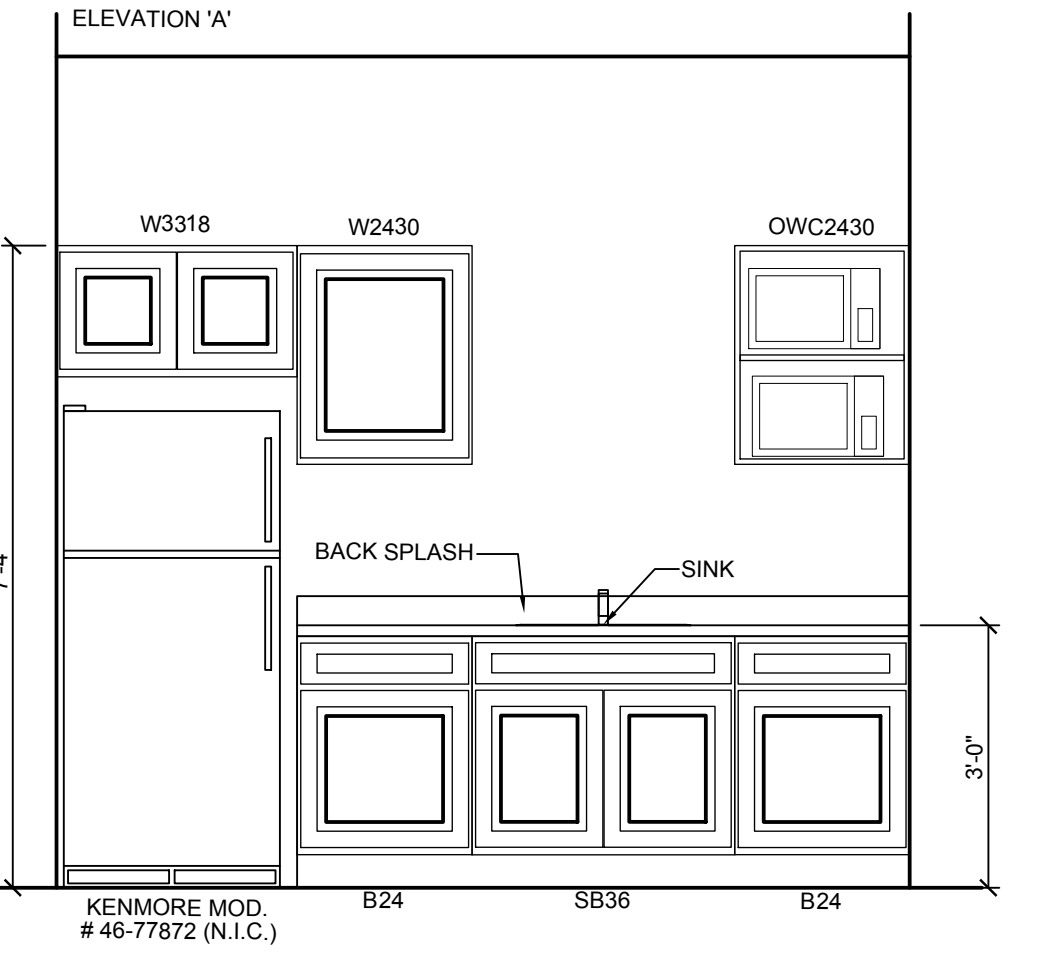

6 INTERIOR ELEVATION
SCALE: 1/2" = 1'-0"

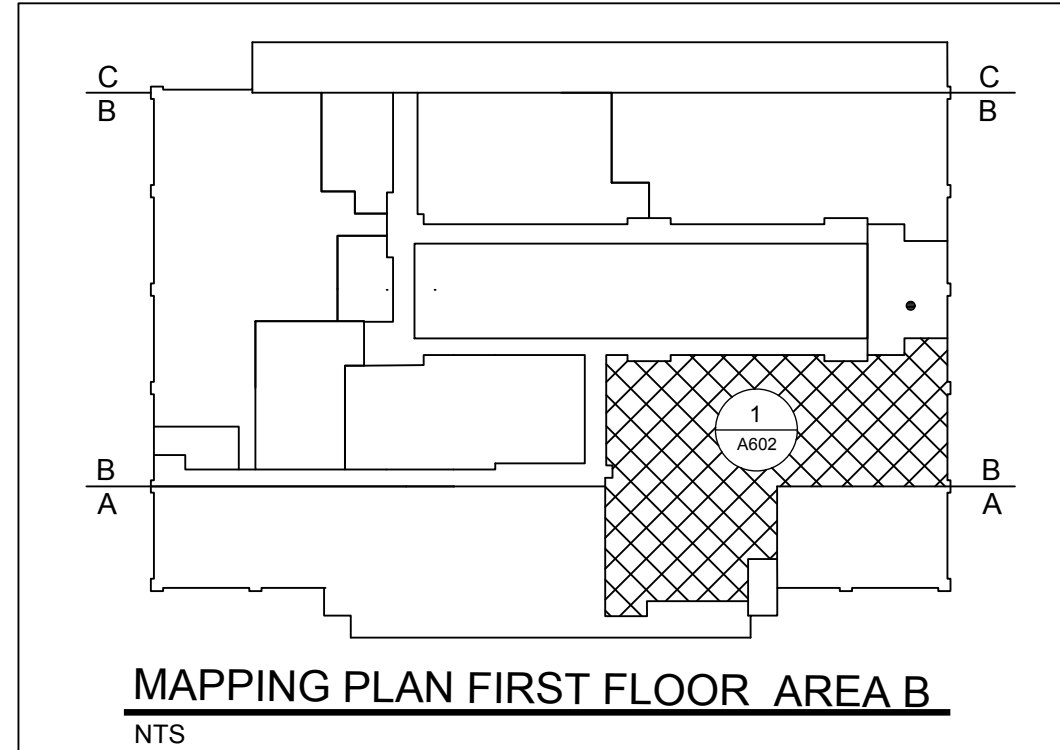

MAPPING PLAN FIRST FLOOR AREA B
NTS

NO.	DATE	REMARKS	NO.	DATE	REMARKS

LEGIBILITY: PRINT THESE DRAWINGS ON ARCHITECTURAL PAPER APPROVED BY THE BOARD OF PROFESSIONAL ENGINEERS AND SURVEYORS OF THE STATE OF MARYLAND.
KERRI WOOD LITTLE, INC. 2027
LITTLEWOOD DRIVE, FORT LEE, VA 22041

ARCHITECTURE
ENGINEERING
INCORPORATED
IOTT
310 HAMMOND ST. SUITE 109 SALISBURY, MARYLAND
(410) 749-7229 • FAX (410) 749-0001

TRI - COUNTY MULTI-PURPOSE CENTER
BUILDING ENVELOPE AND
INTERIOR RENOVATION
SALISBURY, MARYLAND
DLLR SPACE PLAN

PRINT DATE: 11.12.2010
IOTT PROJ. NO.: 09-035
DESIGN BY: JI
SCALE: AS NOTED
STAGE: ISSUED FOR BID
DWG. FILE: 09-035-A602

A
602